

XEAMOS

Reducing emissions together

Clean air engineering



DEATS FB

Dual Exhaust After Treatment System with Fuel Burner

XEAMOS supports yachts to be future proof Harmful NOx emissions in diesel exhaust gases are limited by the IMO Tier III legislation that is mandatory in NOx Emission Control Area's (NECA's). The coastal waters of North America and the Caribbean are designated NECA's for yachts above 500 GT when the ship's keel is laid after January 1st, 2016. More NECA's are expected in the near future.

Our unique "All-in-one" DEATS system consists of a combined silencer/catalyst housing with an integrated DPF and SCR system.

- IMO Tier III certified in combination with various engines, for both refit and new build.
- An automatic safety bypass allows 100% engine availability.
- In practice VIP guests will not experience particulates on deck, common diesel fuel in swimming water and the smell of diesel fuel.
- Compact size. As the urea injector and mixer are integrated in the catalyst housing, the overall installation length is much shorter than any other DPF/SCR combination.
- Fuel burner regenerated.
- The intelligent PLC controlled regeneration system ensures a trouble-free operation of your filter system.

System certification

XEAMOS systems are supplied with the required GDA and IMO Tier III EIAPP certificates. We hold and maintain multiple IMO Tier III certificates for various engine types. Please consult Xeamos for available certificates.

Main Features

- Compact design.
- Burner air supply pump included.
- Active regeneration fuel burner system.
- Lloyd's Register approved.
- Safety By-pass valve for 100% engine availability.
- Integrated sound attenuation function.
- Advanced controller.

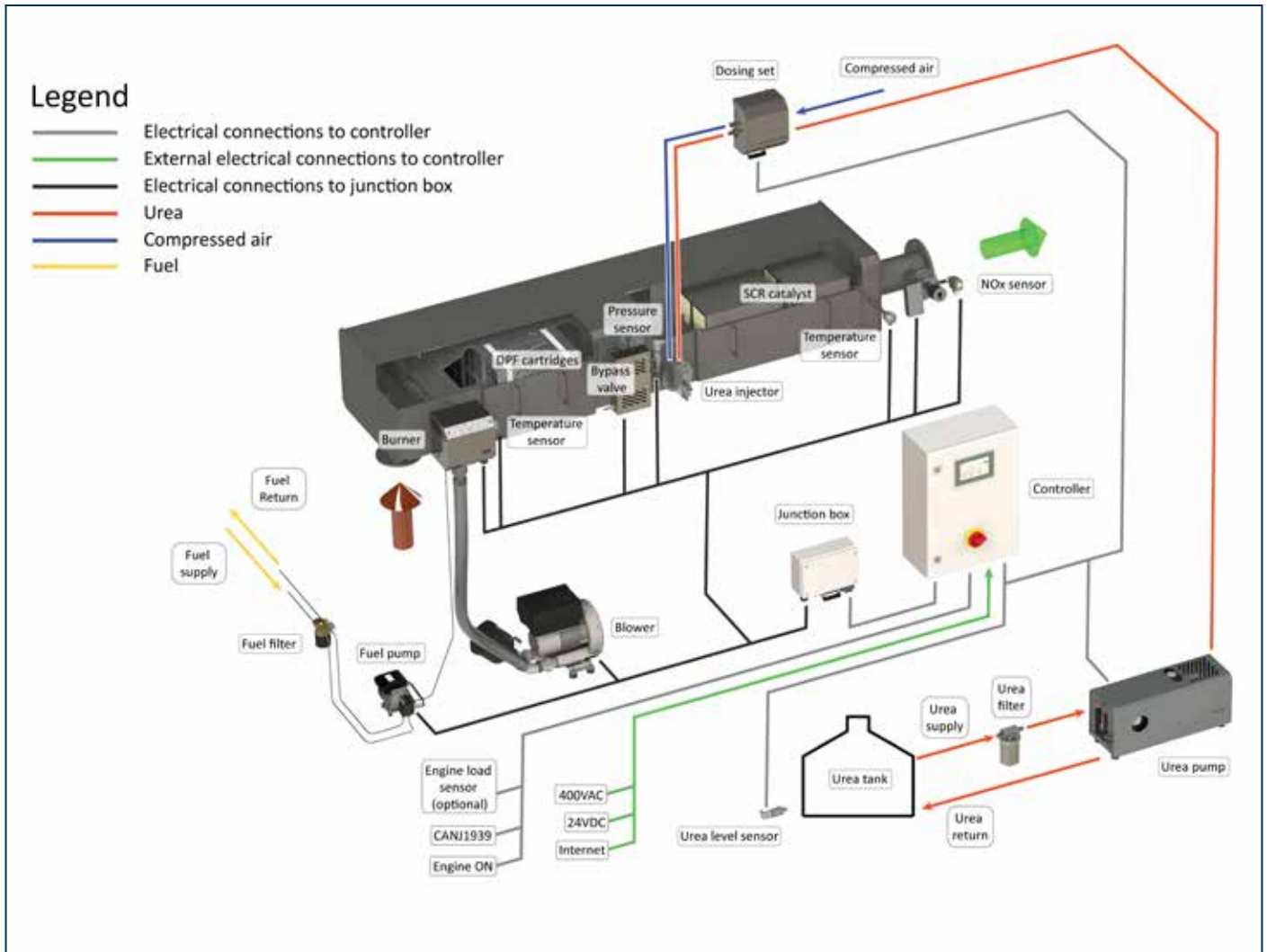

Lay-out of a DEATS FB system.

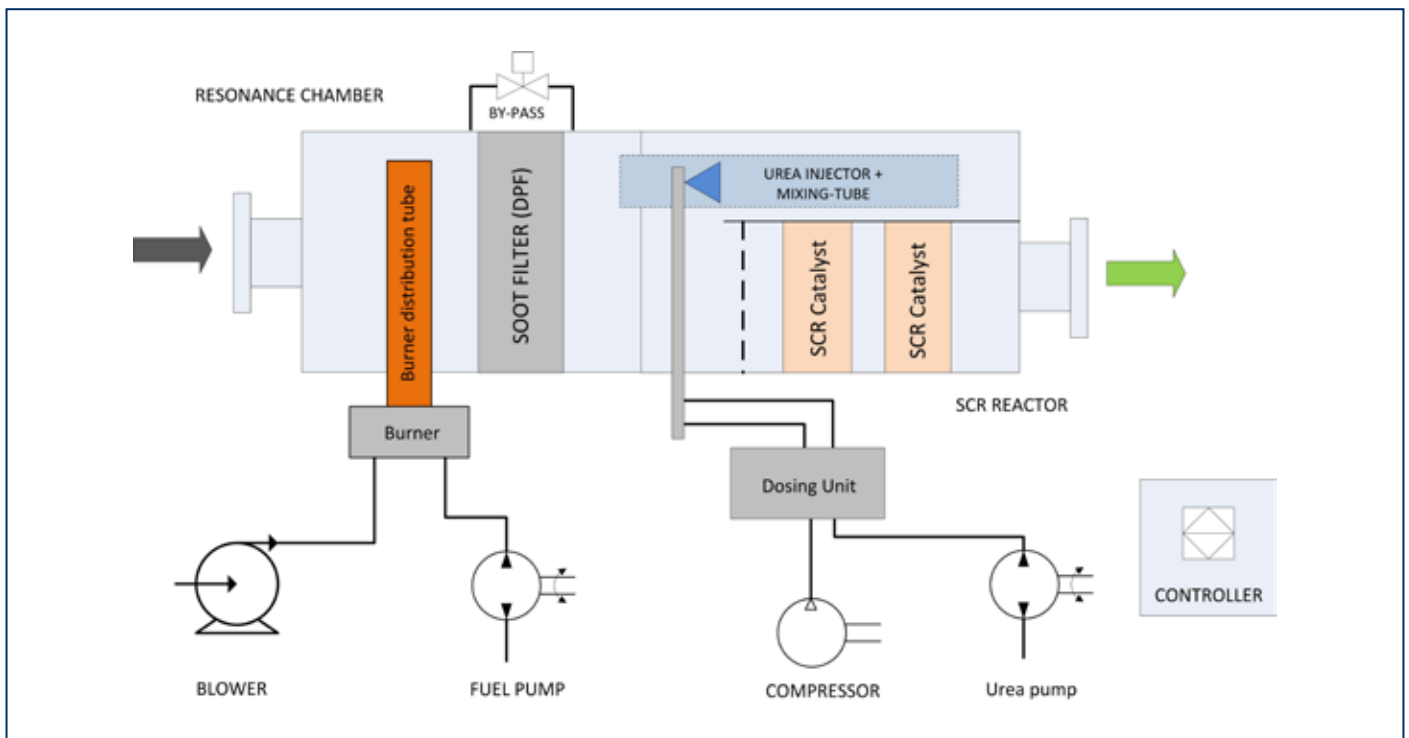

Process schematic of a DEATS FB system.



Operational conditions

Application	Super yachts, and maritime
Exhaust system	Suitable for dry or wet systems
Environment	Engine room, clean
Ambient Temperature	-20 + 55°C
Degree of Protection	IP55
Relative humidity	5 to 95% Non-condensing
Inspection & service interval	Approximately 1x per year (normal conditions)
Compressed air for urea atomizer	8-12 Nm ³ /h @ min. 6 barg
Urea nozzle type	2-phase nozzle, compressed air atomization
Urea specification	AUS32 or AUS40 or equivalent

Supplies

Fuel	EN590 (Diesel), DMA, DMX, max 2000 ppm sulphur
AC Power supply	3 x 400 VAC (4 wire)
DC Power supply	24 VDC - 10A (uninterrupted)

Design data

Materials	Reactor housing: Alloy steel Burner tube and shields: High heat resistant steel
Surface treatment	High temperature coating
Max system pressure	150 mbar (reactor design) - design temperature 520°C
Pressure drop (ΔP)	Approximately 30-40 mbar, clean without soot and ash
DPF type	SiSiC
Coating	BM, SX, ZX (ULSF only)
Emission reduction	NO _x ca. 80% to reach IMO III Tier limit of ca. 2 g/kWh
Operational temperature	>220°C (EN590 fuel) >250°C (max 2000 ppm sulphur)
Control strategy	Closed loop with NO _x sensor
Supports	Bottom - standard, optional top
Thermal insulation	Blankets or cladded insulation (by customer)

Legal requirements and standards

Standards	EMC directive 2014/30/EU Machinery directive 2006/42/EC Low voltage directive 2014/35/EU Thermo processing EN 746-2
Classification	Lloyds Register

System parts

Controller	PLC with full colour HMI, super yacht standard (acc. to LR requirements) - Inputs: engine load, engine on - Outputs: System ON, Alarm, MOD bus - Datalogging - Remote access prepared
Reactor Housing	Flat rectangular shape to reduce overall volume
Blower unit	Blower with 3 phase motor with FC drive, air filter, check valve, filter service switch
Burner	Fuel burner with flame detection and ignition
Fuel set	Fuel pump with shut-off valves
Urea dosing unit	Controls urea and air flow
Urea pump set	Pressurizes urea. Can feed multiple dosing systems
Urea injector	2-phase urea injector, air assisted
Sensors	Temperature & pressure transmitter
Wiring	Wiring by yard on terminals and connectors

Performance

NO _x - Nitrogen oxides	> 80 - 90% reduction
PM (measured as PM 10)	> 97% reduction
Sound attenuation	35 - 40 dB(A)

Optional

- Various catalytic coating for increased HC reduction at low exhaust temperatures
- Remote access via LAN accessible for diagnostics/remote Services
- Alternative power supplies
- Alternative in- and outlet positions and flanges

* Ask Xeamos for advice regarding available catalytic DPF coatings



Dual Exhaust After Treatment System - Fuel Burner

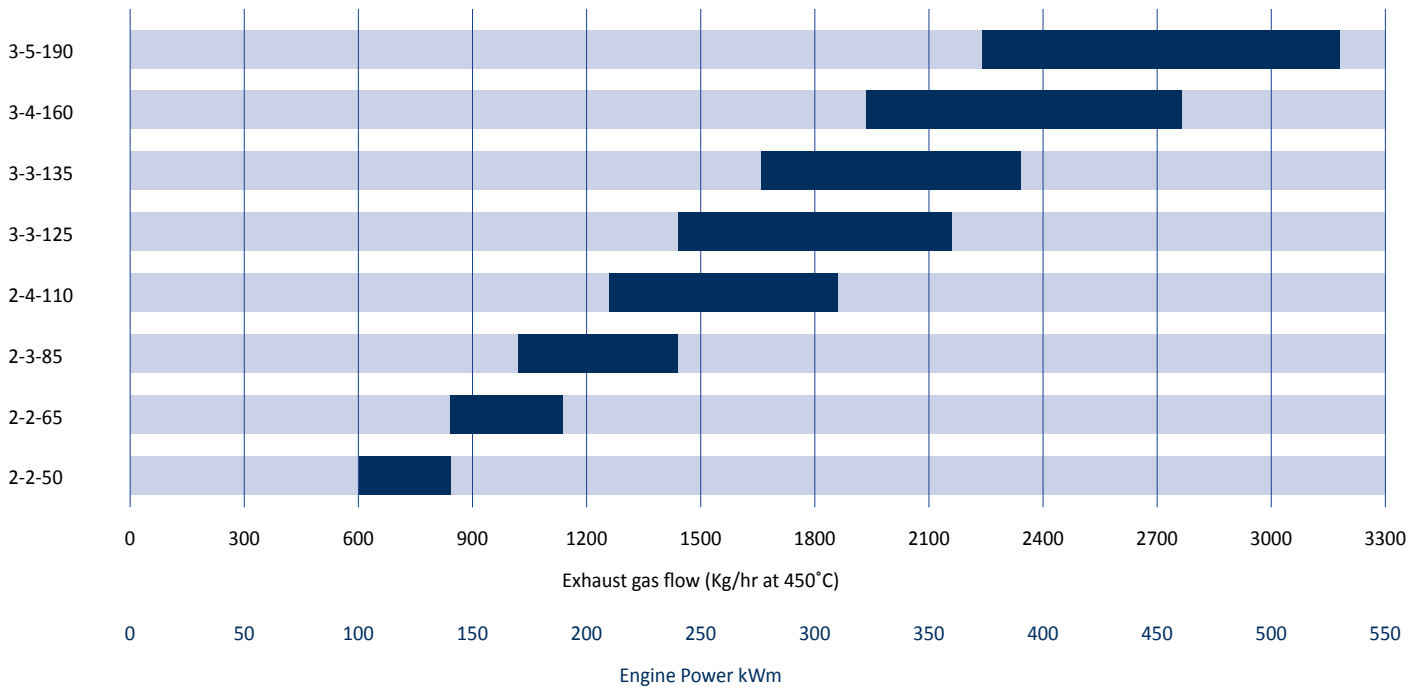

For indication only, please contact us for exact unit selection or custom solutions.

Please consult Xeamos for system sizes 2-4-110 and larger. Application is limited by engine type and fuel type.

Bars in graph correspond with 25-40 mbar pressure drop.

System selection

To configure your system we ask you to submit the following information.

Engine model and power	kW
Engine certification	IMO I / II / other
Exhaust	system wet / dry
Available backpressure	mbar
Running hours per year	hours
Average engine load	%
Lube oil consumption	l/h
Fuel type	

Separate DPF and SCR units

In case a compact solution does not fit in your engine room, a more traditional system can be offered. A separate Zero Soot DPF unit and a Zero NOx SCR unit are then installed in line, connected by the exhaust piping.

Dimensions & options DEATS FB system

Type	DPF volume	Burner	Flanges EN1092 PN10		Hot surface	L1	H1	W1	I1	I2	O1	Supports	Weight
	liter		kW	In									
2-2-50	50	40	DN125	DN150	4,7	2200	435	565	280	130	165	1900x310	400
2-2-65	66	50	DN125	DN150	6,4	2550	435	650	325	130	165	1900x450	480
2-3-85	83	60	DN150	DN200	7,4	2550	435	820	410	130	245	1900x620	600
2-4-110	108	80	DN200	DN200	8,9	2600	435	1080	540	160	320	1900x860	780
3-3-125	124	90	DN200	DN250	9,7	2700	590	840	420	160	245	2300x620	910
3-3-135	137	90	DN200	DN250	10,2	2700	590	940	470	160	245	2300x690	980
3-4-160	162	120	DN200	DN250	11,4	2900	590	1110	555	180	320	2300x860	1140
3-5-190	187	134	DN250	DN300	12,4	2900	590	1250	625	180	400	2300x1010	1370

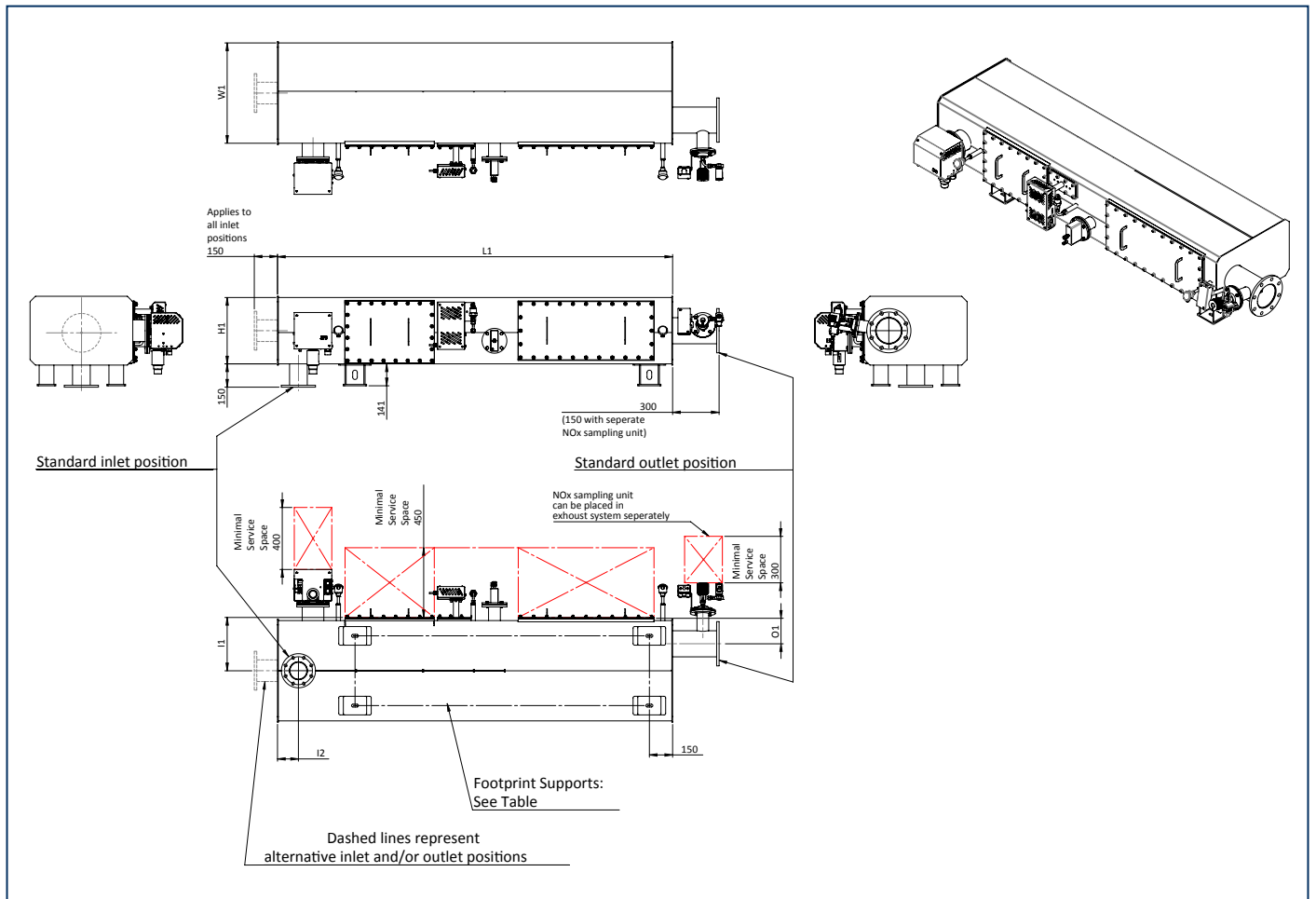

Note: This drawing is preliminary & provided for reference only and is not intended for installation purpose. Contact us either your local distributor for detailed information.

XEAMOS



XEAMOS
Bijsterhuizen 2416 | 6604 LL Wijchen | The Netherlands
+31 (0)246 486 015 | info@xeamos.com

[xeamos.com](https://www.xeamos.com)

Edition 2021-09
DEATS FB

Xeamos™ is a registered trademark. All technical and other data in this brochure is meant for guidance purposes only and the information herein is subject to change without notice. Xeamos BV does not intend any technical data to serve as a warranty; express or implied.